

TECHNICAL SPECIFICATION

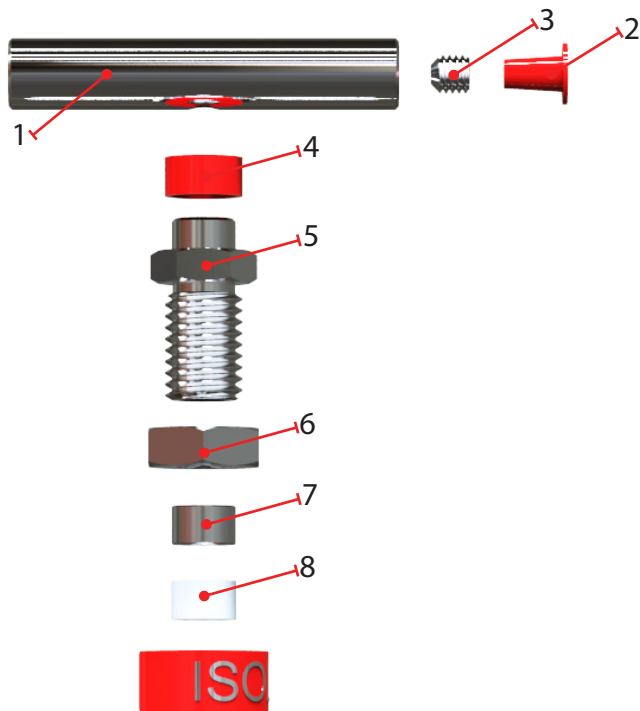

NEEDLE VALVE



DESCRIPTION / MATERIAL

1/	T Bar Handle	316/316L St.St (Dual Cert)
2/	Colour Coded Dust Plug	Polyethylene (LDPE)
3/	Locking screw	304 St.St
4/	Colour Coded Dust Cap	Polyethylene (LDPE)
5/	Gland Adjuster	316/316L St.St (Dual Cert)
6/	Safety Locknut	316/316L St.St (Dual Cert)
7/	Compression Ring	316/316L St.St (Dual Cert)
8/	Packing	PTFE or Graphoil
9/	Valve Bonnet	316/316L St.St (Dual Cert)
10/	Stem Rotating	316/316L St.St (Dual Cert)
11/	Stem Non Rotating	316/316L St.St (Dual Cert)
12/	Locking Pin	304 St.St
13/	Body	316/316L St.St (Dual Cert)

N.B. Wetted parts 9,11, & 13 shown in red

FEATURES

- Gland adjuster packing seal can be externally adjusted in service
- Safety locknut
- Non Rotating stem through packing giving ease of operation & less packing wear
- Stem has back seat for added anti-blow out security
- Standard hard stem tip for effective shut-off
- Stem has rolled threads for smooth action, strength, & long life
- Stem threads above packing, no process contamination or lube washout
- One piece non rotating stem tip joint, located above packing, cannot work free
- Metal to metal bonnet seal suitable for high pressure / temperature applications
- Removable T-bar handle
- Colour coded dust cap on stem prevents ingress of contamination & protects actuating threads

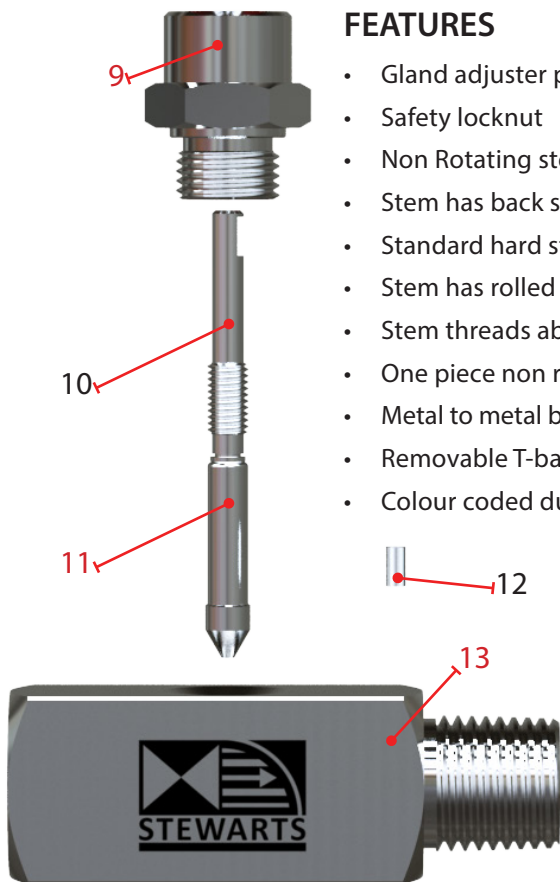

STEWART-BUCHANAN GAUGES LTD

Sales Office & Manufacturing Facility - 7 Garrell Road, Burnside Industrial Estate Kilsyth, Glasgow G65 9JX, SCOTLAND
Tel: +44 (0)1236 821533 | Fax: +44 (0)1236 824090 | E-mail: sales@stewarts-group.com | Web: stewarts-group.com

DATA SHEET REF: NEEDLE TECHNICAL SPECIFICATIONS-REV02-15



NEEDLE VALVE

OPTIONAL FEATURES

- Valves can be supplied to ISO 15156/NACE MR-01-75 or Norsok M-630 specifications
- PMI - Certified material identification XRF (See data sheet)
- Cleaned and degreased for Oxygen service (or Oxidizing Gases)
- Needle valve available in right angled form
- Wide variety of process connections available by arrangement
- Isolating tip as standard, metering tip available on request
- PCTFE (KEL-F) Soft tip option available for special application (Max working temperature = 120°C)
- Panel mounting valve, where available, on request
- Laser etching – customisable options available
- Ø 3.2 Metering tip thru bore (CV = 0.32) Fully open
- Ø 10 Large tip thru bore (CV = 1.7) Fully open
- Firesafe certification to BS EN ISO 10497 (BS 6755 Part 2), API 607, API 6FA, where available
- 10,000psi optional designs, where available
- Choice of exotic alloys i.e., NAB (NiAlBronze), MONEL®, Duplex, Super Duplex, Titanium, HASTELLOY®, Alloys 625, 825, 6%Mo
- All Norsok M-630 materials sourced from Norsok M-650 approved mills on request
- Optional mounting bracket kits, where available



- Packing adjustment may be required during the service life of the valves.
- Valves that have not been cycled over a period of time may have a higher initial actuation torque.
- To increase service life, ensure proper valve performance and prevent leakage, apply only as much torque as is required to achieve positive shutoff.

PRESSURE TEMPERATURE CHART

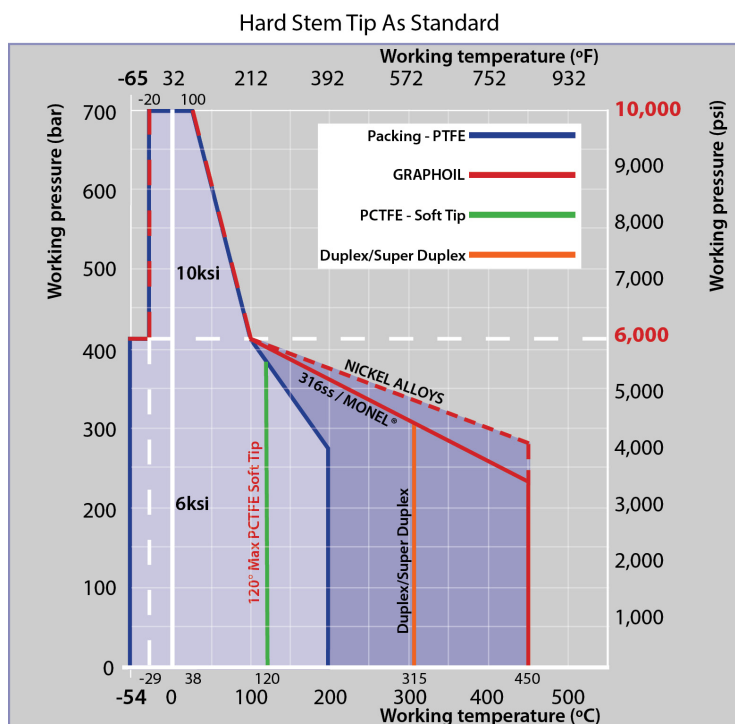

Pressure-Temperature Rating Needle Valves

PTFE PACKING

- Maximum pressure 10000 psi (690 bar) at 100° F (38° C)
- Maximum pressure 6000 psi (413 bar) at 212° F (100° C)
- Maximum pressure 4000 psi (275 bar) at 392° F (200° C)
- (PTFE packing rated to maximum temperature of 392° F (200° C))

GRAPHOIL PACKING

- Maximum pressure 10000 psi (690 bar) at 100° F (38° C)
- Maximum pressure 6000 psi (413 bar) at 212° F (100° C)
- Maximum pressure 3300 psi (230 bar) at 842° F (450° C)

PCTFE Soft Tip

- Maximum pressure 6000 psi (413 bar) at 212° F (100° C)
- Maximum pressure 5500 psi (380 bar) at 248° F (120° C)

Duplex / Super Duplex

- Limited to 600° F (315° C)