



INTRODUCING THE SGM...

The SGM is a manual changeover manifold, mounted onto a stainless steel panel for inert, reactive, flammable, corrosive, and oxidising gases and gas mixtures, with a maximum purity of 6.0.

They are designed to reduce the incoming supply from one gas cylinder up to a maximum of 300 bar (4,350 psi) inlet pressure to a safe and usable. The gas is then delivered through subsequent piping to the point-of-use.

These panels are found in gas cylinder storage rooms, or close to point-of-use. Typical applications include gas supply to analytical instruments and engine emission testing for automotive industries.

The SGM consists of a pressure regulator, relief valve, and upstream shut-off valves, plus an optional purge valve, and inlet and outlet gauges.

FEATURES AND BENEFITS

1 FOR HIGH PURITY GAS ≥ 6.0

Ensures the materials, design, and internal surface finish do not contaminate high purity gases.

2 ERGONOMIC DESIGN

Handwheel and body shape make it easier for technicians to adjust pressures.

3 VISUAL SUPPLY INDICATOR

Arrow indicates which gas cylinder is currently active.

4 HASTELLOY DIAPHRAGM

Hard-wearing for long service life and broad compatibility with speciality gases.

STANDARD MATERIALS OF CONSTRUCTION

PART	MATERIALS
Body and Bonnet	ASTM A479 316/316L Stainless Steel (UNS S31600/S31603)
	Chrome Plated Brass CW614N (UNS C38500)
Main Valve Pin	Hastelloy C276® (UNS N10276)
Soft Seat	PCTFE (Kel-F)
Valve Spring	Inconel® X750 (UNS N07750)
Diaphragm	Hastelloy C22® (UNS N06022)
Handwheel	Anodised Aluminium
O-Rings	FKM/FPM (Viton)
Loading Spring	Spring Steel Grade 80 BS 1449
Filter	100 Microns

Note: Pressure regulator rating may be limited by connection type, Cv and/or seat material. Contact the office for specific pressure or temperature requirements.

SPECIFICATIONS

Max. Inlet	300 bar (4,350 psi)
Max. Outlet	Up to 50 bar (725 psi)
Cv	0.1
Design Proof Pressure	150% max. working pressure
Seat Leakage	$< 1 \times 10^{-6}$ mbar L/s (Helium)
External Leakage	$< 1 \times 10^{-9}$ mbar L/s (Helium)
Purity	≥ 6.0
Min/Max Temperatures	-25°C to +70°C (-13°F to 158°F)
Weights	Up to 6.5kg (14.3lb)
Dimensions	See page 2

Note: Unless otherwise requested, the relief valve's set pressure will be 120% of the regulator's nominal outlet set pressure.

Gas
 Liquid
 Diaphragm
 Piston
 Self-Venting
 Non-Venting
 Max Inlet: 300 bar (4,350 psi)
 Max Outlet: 50 bar (725 psi)
 Cv 0.1

CLEANLINESS STANDARDS & SURFACE FINISH

All components are precision-cleaned to meet stringent cleanliness levels of 1mg/m², in accordance with ASTM G93/G93M, ASTM F331-13, and ISO 15001:2011. Brass products are electroplated as standard to enhance durability and corrosion resistance.

DRAWINGS AND INSTALLATION DIMENSIONS

Dimensions shown for standard configurations only – please contact the office for other options.

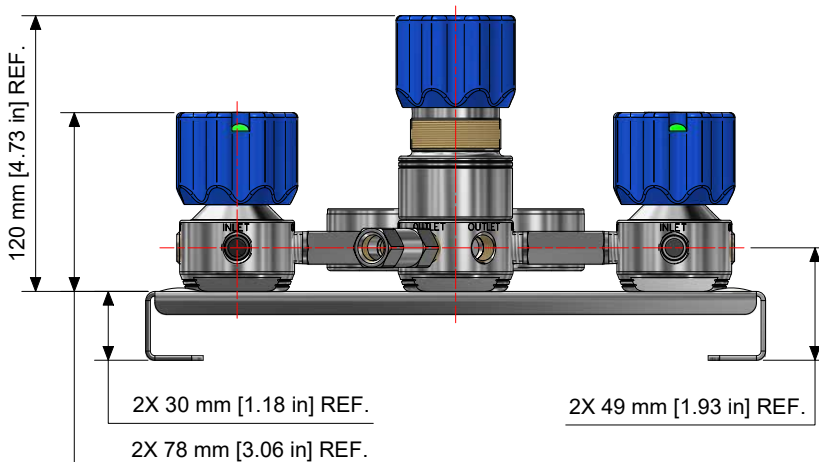
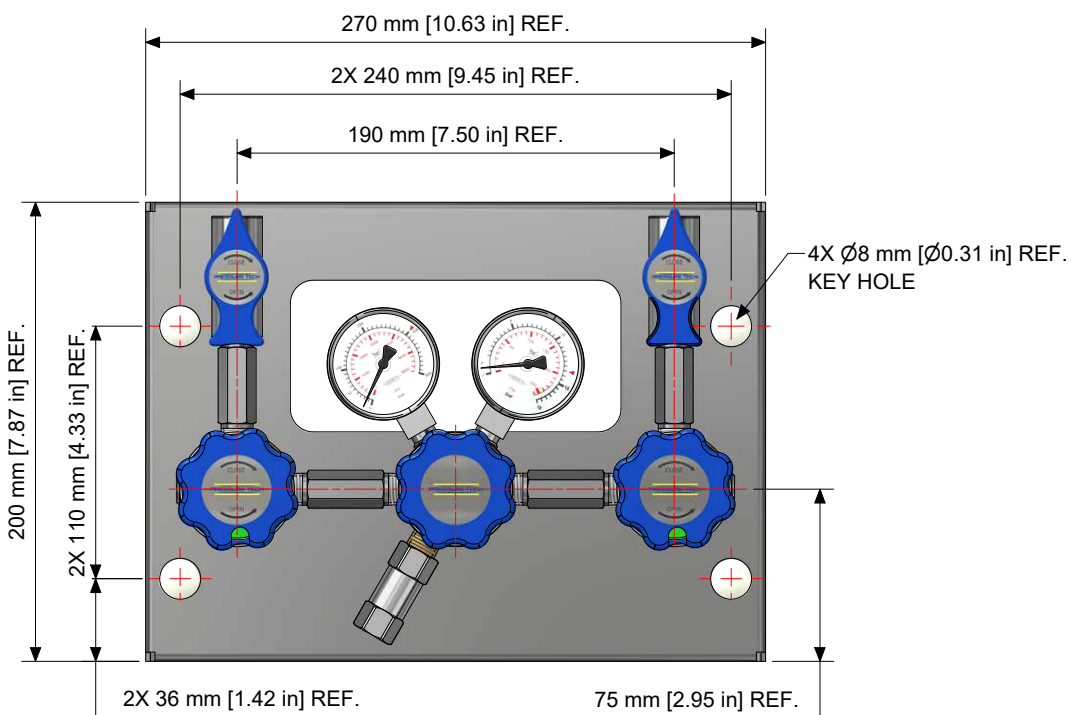

Product availability and specifications contained herein are subject to change without notice. Consult local distributor or factory for potential revisions and/or service related issues. Pressure Tech Ltd support with product selection recommendations only - it is the users responsibility to ensure the product is suitable for their specific application requirements.



PRESSURE TECH LTD

Unit 24, Graphite Way, Hadfield, Glossop, Derbyshire, UK, SK13 1QH
 +44 (0)1457 899 307 | sales@pressure-tech.com | www.pressure-tech.com

DESIGNED, MANUFACTURED AND BUILT IN THE UK

© 2026 Pressure Tech Ltd. All Rights Reserved.

SGM Datasheet

SPECIALITY GAS MANUAL CHANGEOVER MANIFOLD



● Gas ● Liquid | ● Diaphragm ● Piston | ● Self-Venting ● Non-Venting | Max Inlet: 300 bar (4,350 psi) | Max Outlet: 50 bar (725 psi) | Cv 0.1

P&ID

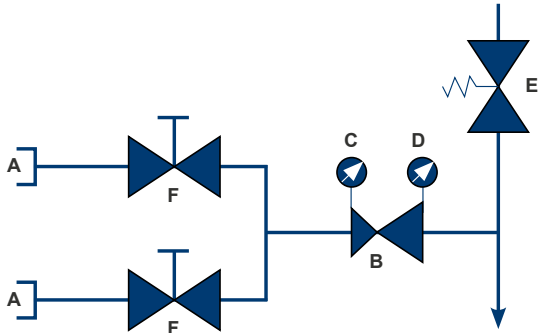

- A: Inlet connection
- B: Pressure regulator
- C: Inlet pressure gauge
- D: Outlet pressure gauge
- E: Relief valve
- F: Upstream shut-off valve

FLOW CURVE

The flow charts for line pressure regulators have been generated in accordance with ISO 2503 which requires the upstream pressure to be approximately twice that of the downstream pressure.

Product availability and specifications contained herein are subject to change without notice. Consult local distributor or factory for potential revisions and/or service related issues. Pressure Tech Ltd support with product selection recommendations only - it is the users responsibility to ensure the product is suitable for their specific application requirements.



PRESSURE TECH LTD

Unit 24, Graphite Way, Hadfield, Glossop, Derbyshire, UK, SK13 1QH
+44 (0)1457 899 307 | sales@pressure-tech.com | www.pressure-tech.com

DESIGNED, MANUFACTURED AND BUILT IN THE UK

© 2026 Pressure Tech Ltd. All Rights Reserved.

310326

PAGE:
3 OF 4

Gas
 Liquid
 |
 Diaphragm
 Piston
 |
 Self-Venting
 Non-Venting
 |
 Max Inlet: 300 bar (4,350 psi)
 |
 Max Outlet: 50 bar (725 psi)
 |
 Cv 0.1

ORDERING INFORMATION

To build a Pressure Tech part number, simply combine the characters identified below in sequence:

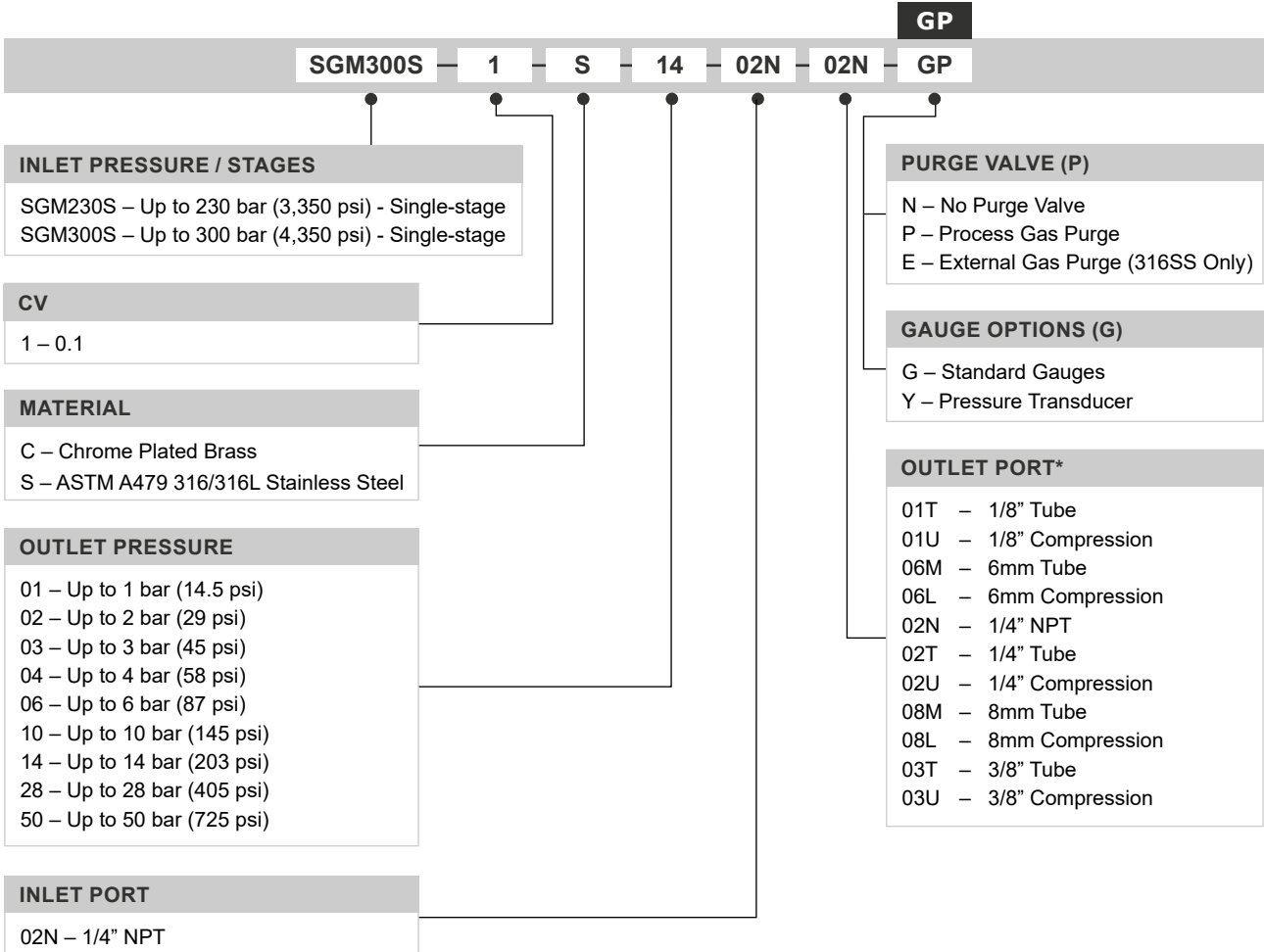

TRADEMARKS: Inconel® is a registered trademark of Inco Alloys International

* Other options available

Product availability and specifications contained herein are subject to change without notice. Consult local distributor or factory for potential revisions and/or service related issues. Pressure Tech Ltd support with product selection recommendations only - it is the users responsibility to ensure the product is suitable for their specific application requirements.



PRESSURE TECH LTD

Unit 24, Graphite Way, Hadfield, Glossop, Derbyshire, UK, SK13 1QH
 +44 (0)1457 899 307 | sales@pressure-tech.com | www.pressure-tech.com

DESIGNED, MANUFACTURED AND BUILT IN THE UK

© 2026 Pressure Tech Ltd. All Rights Reserved.