

LF690 Datasheet

LOW-FLOW PRESSURE REGULATOR



Gas
 Liquid
 Diaphragm
 Piston
 Self-Venting
 Non-Venting
 Max Inlet: 690 bar (10,000 psi)
 Max Outlet: 690 bar (10,000 psi)
 Cv 0.1



INTRODUCING THE LF690...

The LF690 is a piston-sensed low-flow reducing regulator with ceramic seating to provide the ultimate protection against the harsh service encountered on hydraulic applications such as water glycol.

Its unique seating cartridge ensures the main valve is fully supported during operation to prevent 'chattering'. The LF690 is supplied with a segregated captured vent to prevent deterioration to the loading mechanism and making the regulator easier to service.

SPECIFICATION

Max. Rated Inlet Pressure	690 bar (10,000 psi)
Outlet Ranges	Up to 690 bar (10,000 psi)
Design Proof Pressure	150% max. working pressure
Seat Leakage	In accordance with ANSI/FCI 70-3
Weight	4.8kg (10.6lbs)

* Pressure regulator rating may be limited by connection type, Cv and/or seat material

STANDARD MATERIALS OF CONSTRUCTION

PART	MATERIALS
Body and Bonnet	AISI 316/316L Stainless Steel (UNS S31600/S31603)
Main Valve Pin	AISI 316/316L Stainless Steel (UNS S31600/S31603) or Ceramic
Seat	Ceramic
Valve Spring	AISI 302 Stainless Steel (UNS S30200)
Piston	AISI 316/316L Stainless Steel (UNS S31600/S31603)
Handwheel	Nylon
O-Rings	NBR, FKM/FPM or HNBR
Loading Spring	Silicon Chrome Wire

FEATURES AND BENEFITS

1 CERAMIC SEATING DESIGN

Provides the ultimate protection against cavitation on hydraulic services.

2 FULLY SUPPORTED MAIN VALVE

Provides a dampening action to prevent 'chattering'.

3 SEGREGATED CAPTURED VENT

Prevents deterioration to loading mechanism and allows media to be piped off to return tank.

4 EASY ACCESS TO SEAT CARTRIDGE

Simplified servicing through base of regulator.

Product availability and specifications contained herein are subject to change without notice. Consult local distributor or factory for potential revisions and/or service related issues. Pressure Tech Ltd support with product selection recommendations only - it is the users responsibility to ensure the product is suitable for their specific application requirements.



DESIGNED AND BUILT IN THE UK

PRESSURE TECH LTD
 Unit 24, Graphite Way, Hadfield, Glossop, Derbyshire, UK, SK13 1QH
 T +44 (0)1457 899 307
 E sales@pressure-tech.com
 W www.pressure-tech.com

220819

PAGE:
1 OF 4

LF690 Datasheet

LOW-FLOW PRESSURE REGULATOR



● Gas ● Liquid |
 ● Diaphragm ● Piston |
 ● Self-Venting ● Non-Venting |
 Max Inlet: 690 bar (10,000 psi) |
 Max Outlet: 690 bar (10,000 psi) |
 Cv 0.1

DRAWINGS AND INSTALLATION DIMENSIONS

Dimensions shown for 1/4" NPT option - please contact the office for additional connection options.

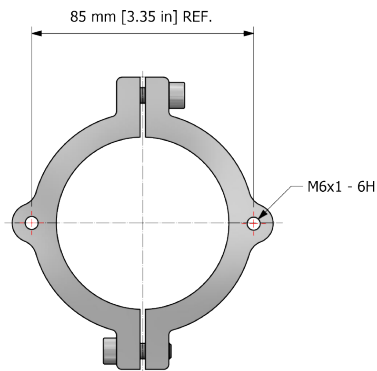
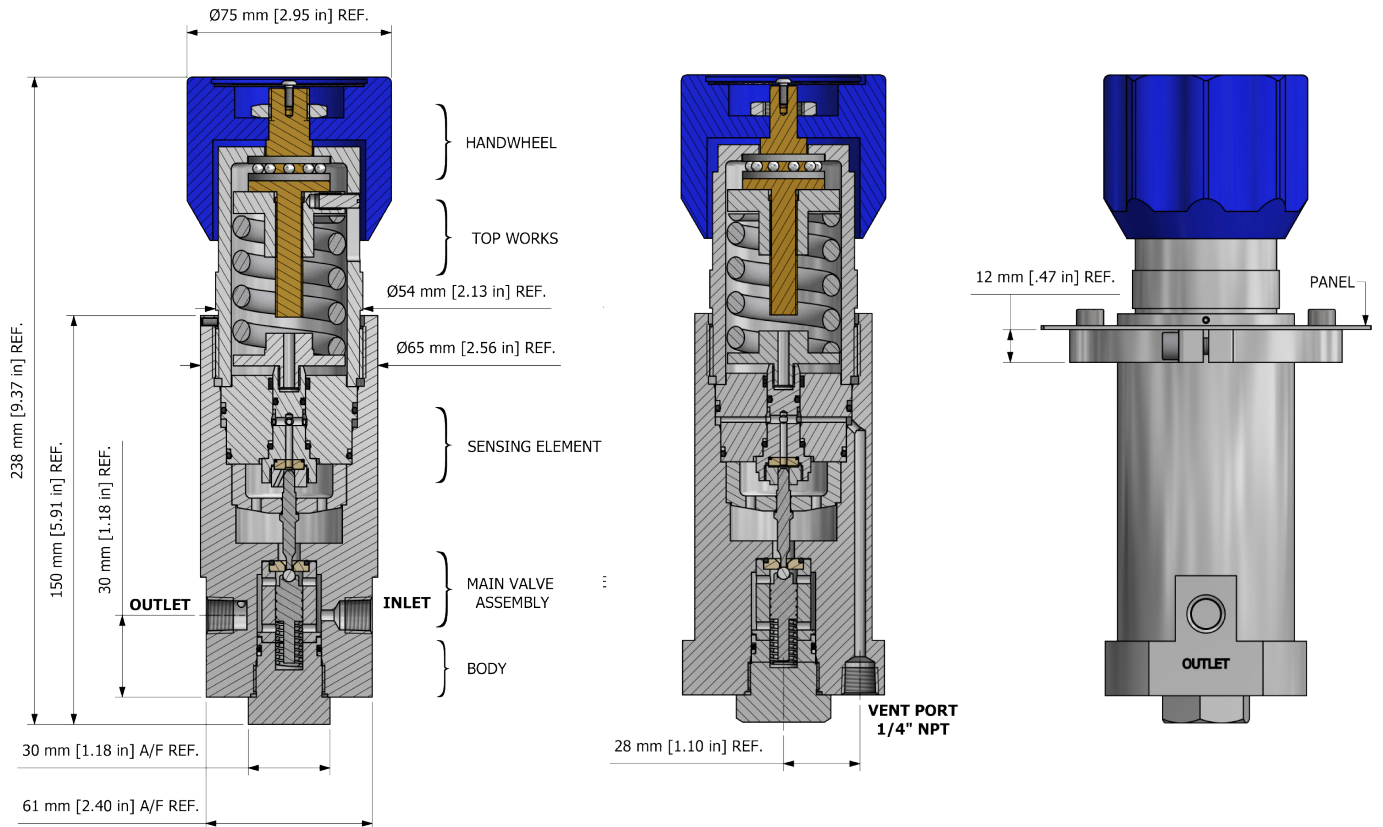

PT-C-061-003-RING (STAINLESS STEEL)
 PT-C-061-003-001-RING (ALUMINIUM)
 PANEL MOUNT RING

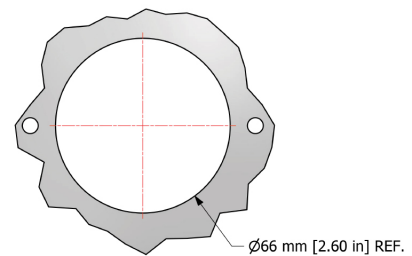

PANEL CUT OUT

Note:

All gauge ports are 1/4" NPT as standard.

Product availability and specifications contained herein are subject to change without notice. Consult local distributor or factory for potential revisions and/or service related issues. Pressure Tech Ltd support with product selection recommendations only - it is the users responsibility to ensure the product is suitable for their specific application requirements.



DESIGNED AND BUILT IN THE UK

PRESSURE TECH LTD
 Unit 24, Graphite Way, Hadfield, Glossop, Derbyshire, UK, SK13 1QH
 T +44 (0)1457 899 307
 E sales@pressure-tech.com
 W www.pressure-tech.com

220819

PAGE:
2 OF 4

LF690 Datasheet

LOW-FLOW PRESSURE REGULATOR



● Gas ● Liquid | ● Diaphragm ● Piston | ● Self-Venting ● Non-Venting | Max Inlet: 690 bar (10,000 psi) | Max Outlet: 690 bar (10,000 psi) | Cv 0.1

FLOW CURVE

Please contact the office for further information.

PORTING CONFIGURATIONS

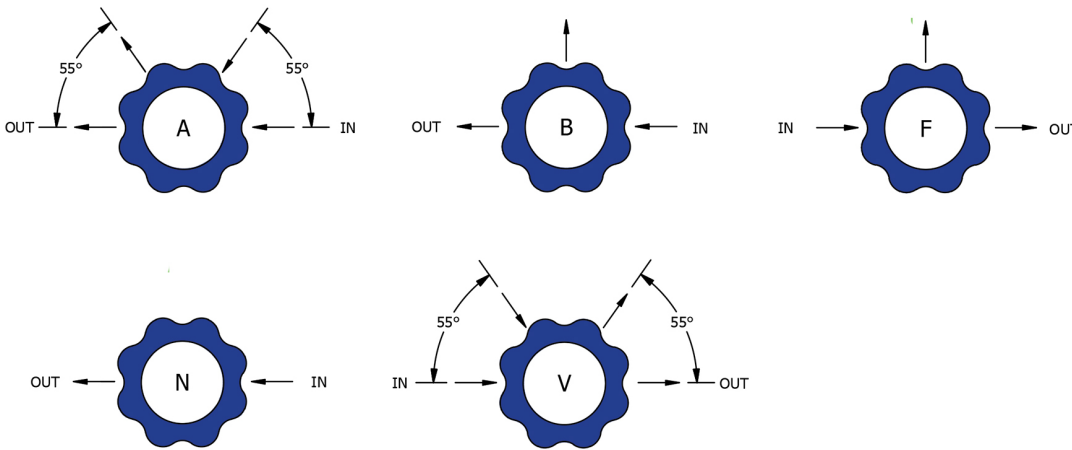

Note:

Additional porting configurations are available - please contact the office for further information.

Product availability and specifications contained herein are subject to change without notice. Consult local distributor or factory for potential revisions and/or service related issues. Pressure Tech Ltd support with product selection recommendations only - it is the users responsibility to ensure the product is suitable for their specific application requirements.



DESIGNED AND BUILT IN THE UK

PRESSURE TECH LTD
Unit 24, Graphite Way, Hadfield, Glossop, Derbyshire, UK, SK13 1QH
T +44 (0)1457 899 307
E sales@pressure-tech.com
W www.pressure-tech.com

220819

PAGE:
3 OF 4

LF690 Datasheet

LOW-FLOW PRESSURE REGULATOR



Gas
 Liquid
 Diaphragm
 Piston
 Self-Venting
 Non-Venting
 Max Inlet: 690 bar (10,000 psi)
 Max Outlet: 690 bar (10,000 psi)
 Cv 0.1

ORDERING INFORMATION

To build a Pressure Tech part number, simply combine the characters identified below in sequence:

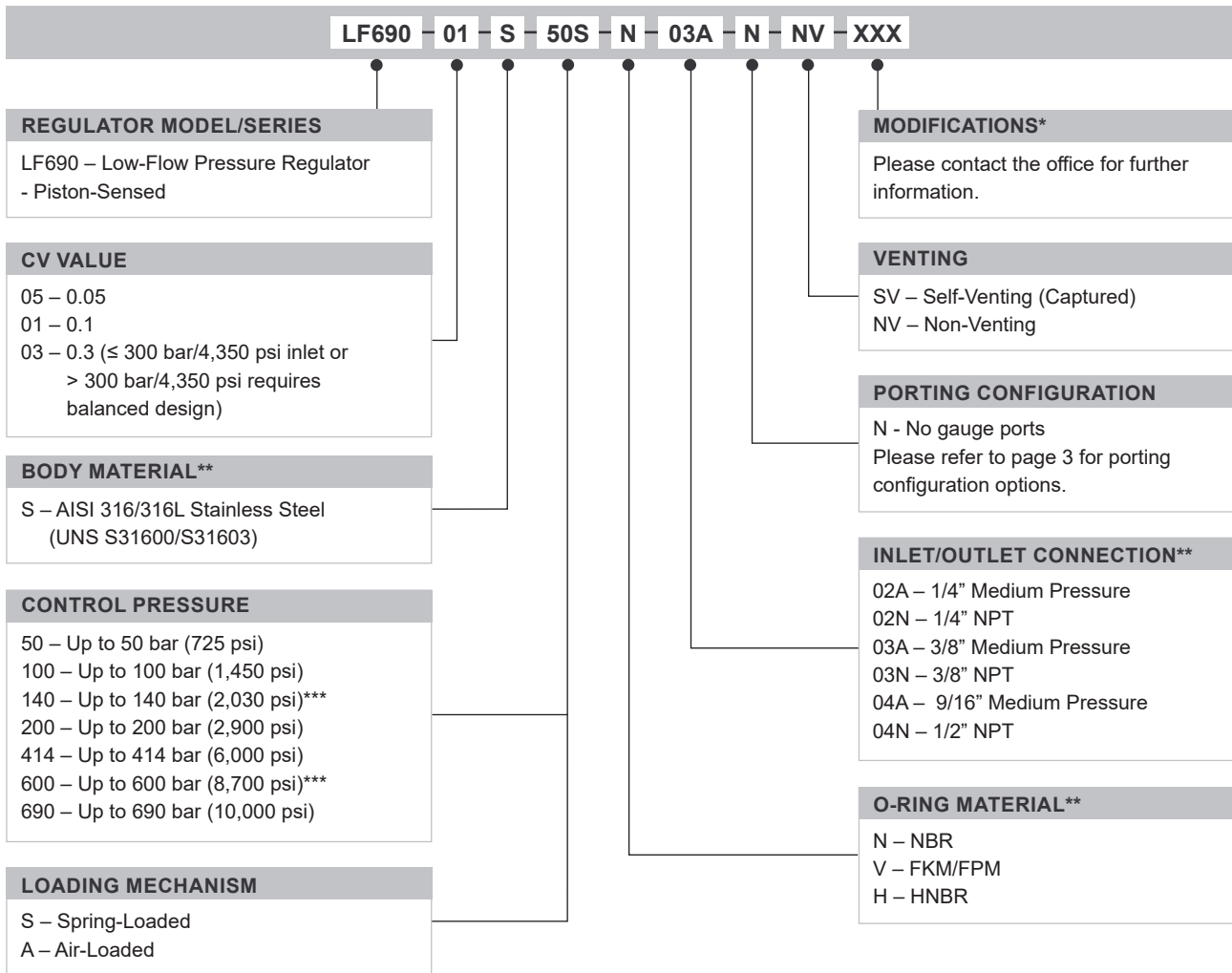

OPTIONAL EXTRAS		
	PART NUMBER	DESCRIPTION
Service Kit	SRK-LF690...	Various options available
Panel Mounting Ring	PT-C-061-003-RING	Stainless Steel panel mount ring
Panel Mounting Ring	PT-C-061-003-001-RING	Aluminium panel mount ring

Note: Ancillary equipment also available.

* Where applicable

*** Air-loaded only

** Other materials / connections may be available - please contact the office

Product availability and specifications contained herein are subject to change without notice. Consult local distributor or factory for potential revisions and/or service related issues. Pressure Tech Ltd support with product selection recommendations only - it is the users responsibility to ensure the product is suitable for their specific application requirements.



DESIGNED AND BUILT IN THE UK

PRESSURE TECH LTD

Unit 24, Graphite Way, Hadfield, Glossop, Derbyshire, UK, SK13 1QH
 T +44 (0)1457 899 307
 E sales@pressure-tech.com
 W www.pressure-tech.com

220819

PAGE:
4 OF 4